

19" Robust & IP65 Industrial Monitor for Rack, Panel, Wall or Arm Mount

- Aluminium front panel meet IP65 standard
- Analog VGA and digital DVI input interface
- Robust steel chassis for shocking and vibration requirement
- High brightness
- Long lifetime panel 50000hrs MTBF
- Resolution 1280 x 1024
- Advanced thermal and air flow design
- Optional: 9 ~ 36V DC power input for mobile application
- Optional: RS-232 interface touch screen
- OSD function in the front panel
- Operation temperature 0 ~ +50°
- Panel mount, rack mount, wall mount or arm mount

Description:

The 19" TFT LCD monitor has a aluminium front panel meet IP65 standard for tough environment. The Display support not only analog VGA but also DVI input. The robust steel chassis protects against shock and vibration. With OSD function in the front panel, user can adjust the monitor such as brightness or contrast and extend the panel life. Optionally are a touch screen possible and a model with a 9 ~ 36V DC input for mobile application is available. Fully mounting ways supports rack mount, panel mount, wall mount or arm mount.



Specification:

Panel type: XGA TFT LCD
 LCD size: 19"
 Max. resolution: 1280 x 1024
 Brightness: 300 cd/m2
 Contrast ratio: 700:1
 LCD color: 16.2M
 Pixel pitch: 0.264mm
 View angel (H/V): 140/130
 Input: Analog VGA and Digital DVI
 LCD MTBF: 50.000hrs
 Backlight MTBF: 30.000 hrs
 OSD: control key in front panel
 Front panel: aluminium meet IP65
 Chassis: heavy-duty steel
 Power adapter: 45WAC
 Mounting: wall, panel, rack, arm
 Dimension: 482 x 399 x 73mm
 Panelcut: 447 x 360mm

Operation temperature: 0°C ~ +50°C
 Relative humidity: 5 ~ 95% non condensing
 Vibration: 5 ~ 17 Hz, 0.1" double amplitude displacement, 17 ~ 640Hz, 1.5G acceleration peak to peak
 Shock: 10G acceleration peak to peak (11ms)
 Net weight: 19kg

TOUCH SCREEN (optional):

Type: Analog resistive
 Resolution: 4096 x 4096 dpi (based on controller resolution)
 Position accuracy: less than 1.5%
 Electrostatic protection: 30kV (contact/air) Controller: 20kV

Order information:

DM-190-GS

19" LCD monitor, IP65

DM-190-GMS

with 9 ~36V DC input

DM-190-GS/T-R

with touch screen

DM-190-GMS/T-R

9~36V DC and Touch

ACCESSORY:

WK-190MS

wall mountig kit

RK-190MS

rack mounting kit

ARM-31

monitor arm up to 14 kg

DISPLAYS

Touchscreen

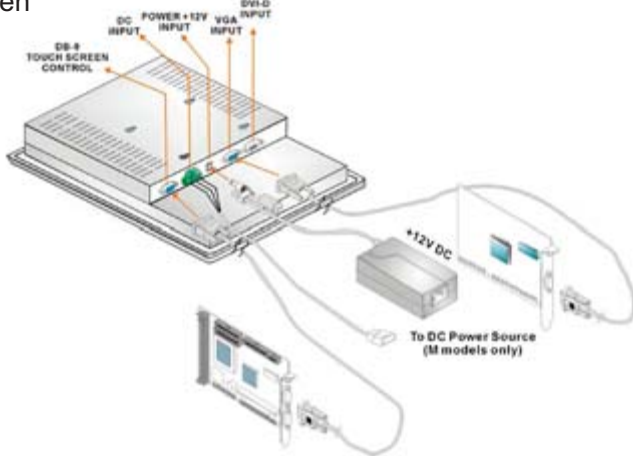

Panel mounting kit: PK-190M

Panelcut: 447 x 360

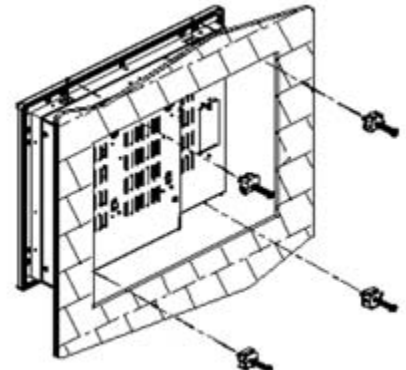

Dimension in mm

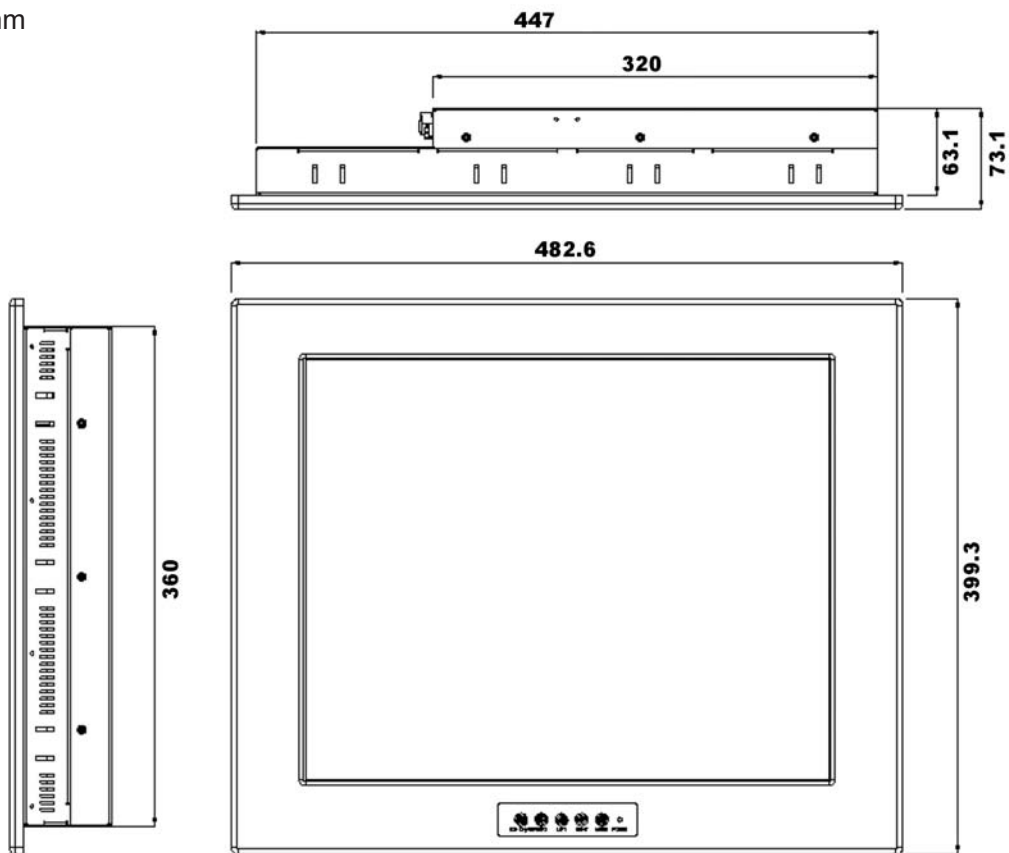

Monitor arm: ARM-31

Rack mounting: RK-190MS-R10

