

# **UNO-2050E**

**GX2-400 Universal Network Controller  
with 2xLAN, 2xRS-232, 2xIsolated  
RS-232/422/485, 16xIsolated DI/O**

## **User Manual**

## **Copyright**

The documentation and the software included with this product are copyrighted 2006 by Advantech Co., Ltd. All rights are reserved. Advantech Co., Ltd. reserves the right to make improvements in the products described in this manual at any time without notice. No part of this manual may be reproduced, copied, translated or transmitted in any form or by any means without the prior written permission of Advantech Co., Ltd. Information provided in this manual is intended to be accurate and reliable. However, Advantech Co., Ltd. assumes no responsibility for its use, nor for any infringements of the rights of third parties, which may result from its use.

## **Acknowledgements**

Intel and Pentium are trademarks of Intel Corporation.

Microsoft Windows and MS-DOS are registered trademarks of Microsoft Corp.

All other product names or trademarks are properties of their respective owners.

Part No. 2003205010

1st Edition

Printed in Taiwan

September 2006

## **Product Warranty (2 years)**

Advantech warrants to you, the original purchaser, that each of its products will be free from defects in materials and workmanship for two years from the date of purchase.

This warranty does not apply to any products which have been repaired or altered by persons other than repair personnel authorized by Advantech, or which have been subject to misuse, abuse, accident or improper installation. Advantech assumes no liability under the terms of this warranty as a consequence of such events.

Because of Advantech's high quality-control standards and rigorous testing, most of our customers never need to use our repair service. If an Advantech product is defective, it will be repaired or replaced at no charge during the warranty period. For out-of-warranty repairs, you will be billed according to the cost of replacement materials, service time and freight. Please consult your dealer for more details.

If you think you have a defective product, follow these steps:

1. Collect all the information about the problem encountered. (For example, CPU speed, Advantech products used, other hardware and software used, etc.) Note anything abnormal and list any onscreen messages you get when the problem occurs.
2. Call your dealer and describe the problem. Please have your manual, product, and any helpful information readily available.
3. If your product is diagnosed as defective, obtain an RMA (return merchandize authorization) number from your dealer. This allows us to process your return more quickly.
4. Carefully pack the defective product, a fully-completed Repair and Replacement Order Card and a photocopy proof of purchase date (such as your sales receipt) in a shippable container. A product returned without proof of the purchase date is not eligible for warranty service.
5. Write the RMA number visibly on the outside of the package and ship it prepaid to your dealer.

## **Declaration of Conformity**

### **CE**

This product has passed the CE test for environmental specifications when shielded cables are used for external wiring. We recommend the use of shielded cables. This kind of cable is available from Advantech. Please contact your local supplier for ordering information.

### **FCC Class A**

Note: This equipment has been tested and found to comply with the limits for a Class A digital device, pursuant to part 15 of the FCC Rules. These limits are designed to provide reasonable protection against harmful interference when the equipment is operated in a commercial environment. This equipment generates, uses, and can radiate radio frequency energy and, if not installed and used in accordance with the instruction manual, may cause harmful interference to radio communications. Operation of this equipment in a residential area is likely to cause harmful interference in which case the user will be required to correct the interference at his own expense.

### **Technical Support and Assistance**

Step 1. Visit the Advantech web site at **[www.advantech.com/support](http://www.advantech.com/support)** where you can find the latest information about the product.

Step 2. Contact your distributor, sales representative, or Advantech's customer service center for technical support if you need additional assistance. Please have the following information ready before you call:

- Product name and serial number
- Description of your peripheral attachments
- Description of your software (operating system, version, application software, etc.)
- A complete description of the problem
- The exact wording of any error messages

# Contents

<b>Chapter 1</b>	<b>Overview .....</b>	<b>2</b>
1.1	Introduction .....	2
1.2	Hardware Specifications .....	2
1.3	Safety Precautions .....	5
1.4	UNO-2050E Series.....	5
1.5	Chassis Dimensions.....	6
	Figure 1.1:Chassis Dimensions .....	6
2.1	UNO-2050E Peripherals .....	8
	Figure 2.1:UNO-2050E Front Panel .....	8
	Figure 2.2:UNO-2050E Rear Panel .....	8
2.2	COM1 & 2: RS-232 Interfaces.....	8
2.3	COM3 & 4: Isolated 5-wire RS-232/422/485 .....	8
	Table 2.1:Serial Port Default Setting .....	8
2.4	Onboard Isolated Digital Input.....	9
	Figure 2.3:Digital Input Connector Pin Assigns .....	9
	Table 2.2:Digital Input Signal Description .....	10
	Figure 2.4:Isolated Digital Input Connection .....	10
	Table 2.3:Interrupt Control Register Bit Map .....	11
	Table 2.4:Interrupt Disable/Enable C. Bit Values .....	12
	Table 2.5:Interrupt Triggering Edge C. Bit Values .....	12
	Table 2.6:Interrupt Flag Bit Values .....	12
2.5	Onboard Isolated Digital Output.....	13
	Figure 2.5:Digital Output Connector Pin Assigns .....	13
	Table 2.7:Digital Output Signal Description .....	13
	Table 2.8:JP12 DO Power On Configuration .....	14
	Figure 2.6:Isolated Digital Output Connection .....	14
2.6	Onboard Isolated Counter/Timer .....	15
	Table 2.9:Counter/Timer Control Register Bit Map ....	16
	Figure 2.7:Counter 0 Function Block .....	17
	Figure 2.8:Counter 1 Function Block .....	17
	Figure 2.9:32-bit Counter Function Block .....	18
	Table 2.10:Counter Clock Source Control Bit .....	18
	Table 2.11:Counter Internal Clock Control Bit .....	18
	Table 2.12:Counter Gate Source Control Bit .....	19
	Table 2.13:Counter Output Destination .....	19
	Table 2.14:Counter Interrupt Flag Control Bit .....	20
	Table 2.15:32-bit Counter Control Bit .....	20
2.7	LAN: Ethernet Connector .....	20
2.8	Power Connector .....	21
2.9	LED Indicators .....	21
2.10	PS/2 Keyboard and Mouse Connector .....	21
2.11	VGA: VGA Display Connector .....	21
2.12	Programmable LED and Buzzer .....	21
	Table 2.16:LED & Buzzer Control Register Bit Map .	21
	Table 2.17:Programmable LED Control Bit .....	22
	Table 2.18:Programmable Buzzer Control Bit .....	22
2.13	RESET: Reset Button.....	22

<b>Chapter</b>	<b>3</b>	<b>Initial Setup.....</b>	<b>24</b>
	3.1	Insert CompactFlash Card .....	24
	3.2	Chassis Grounding .....	24
		Figure 3.1:Chassis Grounding Connection .....	24
	3.3	Connect the Power .....	25
	3.4	Wiring Considerations.....	25
	3.5	BIOS Setup and System Assignments .....	25
	3.6	HDD Extension Flexibility.....	26
<b>Appendix</b>	<b>A</b>	<b>Pin Assignments .....</b>	<b>28</b>
	A.1	Board Connector and Jumpers .....	28
		Figure A.1:Connector & Jumper Locations (Top) .....	28
		Figure A.2:Connector & Jumper Locations (Bottom) .....	28
		Table A.1:UNO-2050E Connectors & Jumpers .....	29
	A.2	Standard RS-232 Serial Port .....	30
		Table A.2:RS-232 Serial Port Assignments .....	30
	A.3	Isolated RS-232/422/485 Ports.....	31
		Table A.3:Isolated RS-232/422/485 Port Assigns .....	31
		Table A.4:Jumpers to Select RS-232/422/485 .....	31
		Table A.5:Auto Flow&Master/Slave Select .....	32
		Table A.6:JP7 RS-422/485 Terminal Resistor Setting .....	33
		Figure A.3:RS-485 Wiring Topology .....	34
	A.4	Ethernet RJ-45 Connector (LAN1~LAN2).....	34
		Table A.7:Ethernet RJ-45 Connector Pin Assigns .....	34
	A.5	Phoenix Power Connector (CN3).....	35
		Table A.8:Phoenix Power Connector Pin Assigns .....	35
	A.6	PS/2 Keyboard & Mouse Connector.....	35
		Table A.9:Keyboard & Mouse Connector Pin Assigns .....	35
	A.7	VGA Display Connector (VGA1).....	36
		Table A.10:VGA Adaptor Cable Pin Assigns .....	36
	A.8	CompactFlash Master/Slave Jumper Settings (JP3).....	37
	A.9	Enhanced IDE Connector (CN2).....	38
		Table A.11:IDE Hard Drive Connector .....	38
	A.10	UNO-2050E Control Register .....	39
		Table A.12:UNO-2050E Control Register .....	39

## Overview

This chapter gives background information on the UNO-2050E, including an overview and specifications.

Sections include:

- Introduction
- Hardware Specifications
- Safety Precautions
- UNO-2050E Series
- Chassis Dimensions

# Chapter 1 Overview

## 1.1 Introduction

---

Leveraging field-approved and worldwide-awareness real-time OS technology, Advantech UNO-2000 series provides Windows CE & XPe SP2 ready solution and support several standard networking interfaces, such as Ethernet, Wireless LAN, RS-232/422/485 and more. Because of its openness, great expansion capability and reliable design – fanless and diskless, Advantech UNO-2000 series becomes an ideal embedded platform to implement custom applications in diversified applications.

## 1.2 Hardware Specifications

---

**CPU:** AMD Geode GX533-400

**Chipset:** AMD CS5535

**BIOS:** AWARD 4Mbit FLASH BIOS

**RAM:** 256MB DDR RAM on board

**VGA:** Supports VGA and VESA

- Display memory: 1 ~ 16 MB share memory, set in BIOS
- CRT display mode: Non-interlaced CRT monitors resolutions up to 1280 x 1024 @ 256 colors or 1024 x 768 @ 24 bit
- DB-15 VGA connector

**Serial Port:** Two standard RS-232 ports

- Data bits: 5, 6, 7, 8
- Stop bits: 1, 1.5, 2
- Parity: none, even, odd
- Speed: 50~115.2K bps
- Data signals: TxD, RxD, RTS, CTS, DTR, DSR, DCD, RI, GND
- Max data distance: 50 feet (15.2 meters)

**Serial Port:** 2 x 5-wire RS-232/422/485

- Automatic RS-485 data flow control
- 2000 V<sub>DC</sub> surge protection and 1500 V<sub>DC</sub> isolation
- Stop bits: 1, 1.5, 2

- Parity: non, even, odd
- RS-232 Speed: 50 ~ 230.4 Kbps
- RS-422/485 speed: 50 ~ 921.6 Kbps
- 5-wire RS-232 data signals: TxD, RxD, RTS, CTS, GND
- RS-422 data signals: TxD+, TxD-, RxD+, RxD-, GND
- RS-485 data signals: DATA+, DATA-, GND
- RS-232 max data distance: 50 feet (15.2 meters)
- RS-422/485 max data distance: 4000 feet (1200 meters)
- Plug-in screw-terminal block: Accepts 0.5 mm<sup>2</sup> to 2.5 mm<sup>2</sup>,  
1 - #12 or 2 - #14 to #22 AWG

**Ethernet Port:** Dual 10/100Base-T Ethernet

- LAN chip: Realtek 8139DL chipset supports
- LED on the front side

**8-ch Isolated Digital Input:** (DI0~DI7)

- 2,000 V<sub>DC</sub> isolation, 2000 V<sub>DC</sub> ESD protection and 70 V<sub>DC</sub>  
over-voltage protection
- 0 ~ 50 V<sub>DC</sub> input range and 10 KHz speed
- Input Voltage
- Logic 0: 0 ~ 3 V<sub>DC</sub>
- Logic 1: 10 ~ 50 V<sub>DC</sub>
- Input Current
- 10 V<sub>DC</sub>: 1.7 mA (typical)
- 12 V<sub>DC</sub>: 2.1 mA (typical)
- 24 V<sub>DC</sub>: 4.4 mA (typical)
- 48 V<sub>DC</sub>: 9.0 mA (typical)
- 50 V<sub>DC</sub>: 9.4 mA (typical)
- Interrupt handling capability
- Plug-in screw-terminal block: Accepts 0.5 mm<sup>2</sup> to 2.5 mm<sup>2</sup>, 1 -  
#12 or 2 - #14 to #22 AWG

**8-ch Isolated Digital Output: (DO0 ~ DO7)**

- 2,000 V<sub>DC</sub> isolation and 200 mA max / channel sink current
- Keep output status after system hot reset
- 5 ~ 40 V<sub>DC</sub> output range and 10 KHz speed
- Plug-in screw-terminal block: Accepts 0.5 mm<sup>2</sup> to 2.5 mm<sup>2</sup>,  
1 - #12 or 2 - #14 to #22 AWG

**Two 16-bit Counters/Timers:**

- Counter source: DI6 & DI7, Pulse output: DO6 & DO7
- Can be cascaded as one 32-bit counter/timer
- Down counting, Preset counting value
- Interrupt handling, speed: 10 KHz
- Timer time base: 100 KHz, 10 KHz, 1 KHz, 100 Hz

**SSD:** One Type I / Type II CompactFlash card slot inside the chassis

**HDD:** Offers HDD Extension kit for installation of 1 standard 2.5" HDD.

**LED:** 1 power LED, 1 IDE LED, 1 programmable LED and buzzer

**Keyboard/Mouse Connector:** Mini Din Connector Supports  
PS/2 keyboard and mouse

**Power Supply Voltage:** 9 ~ 30 V<sub>DC</sub>, reversed wiring protection

**Power Consumption:** 0.45 A max under +24 V power input or  
0.9 A max.under +12 V power input

**Power Requirement:** 1A typical under +24 V power input or  
1.5 A typical under +12 V power input

**Operating Temperature:** -10 ~ 55° C (14 ~ 131° F)

**Chassis Size (WxLxH):** 164.8 x 106.5 x 35.5 mm (6.5" x 4.2" x 1.4")

**Weight:** 0.8 kg

## 1.3 Safety Precautions

---

The following sections tell how to make each connection. In most cases, you will simply need to connect a standard cable. All of the connector pin assignments are shown in Appendix A.

**Warning!** Always disconnect the power cord from your chassis whenever you are working on it. Do not connect while the power is on. A sudden rush of power can damage sensitive electronic components.

**Caution!** Always ground yourself to remove any static electric charge before touching UNO-2050E. Modern electronic devices are very sensitive to static electric charges. Place all electronic components on a static-dissipative surface or in a static-shielded bag.

## 1.4 UNO-2050E Series

---

There are three products in UNO-2050E series as listed as below:

- **UNO-2050E:** UNO-2050E hardware platform
- **UNO-2050ECE:** UNO-2050E hardware platform with Windows CE OS (built in 128MB CompactFlash card)
- **UNO-2050EXP:** UNO-2050E hardware platform with Windows XP SP2 (built in 1GB CompactFlash card)

### Packing list

Before installing your board, make sure that the following materials have been received:

- Warranty certificate
- Software Supporting CD-ROM
- 6P-6P-6P 20cm KB and PS/2 Mouse Y cable (P/N: 1700060202)
- Plug-in Block 2P Female (P/N 1652002205)
- DIN-rail mounting accessory (1997001110, 1997001120, 1997001130, 1997001140)

### For UNO-2050ECE only:

- Built in 128 MB CompactFlash card with Microsoft Windows CE OS
- End User License Agreement for Windows CE

**For UNO-2050EXP only**

- Built in 1GB CompactFlash card with Microsoft WinXPE SP2
- End user License Agreement for Windows XPE

If any of these items are missing or damaged, contact your distributor or sales representative immediately.

## 1.5 Chassis Dimensions

---

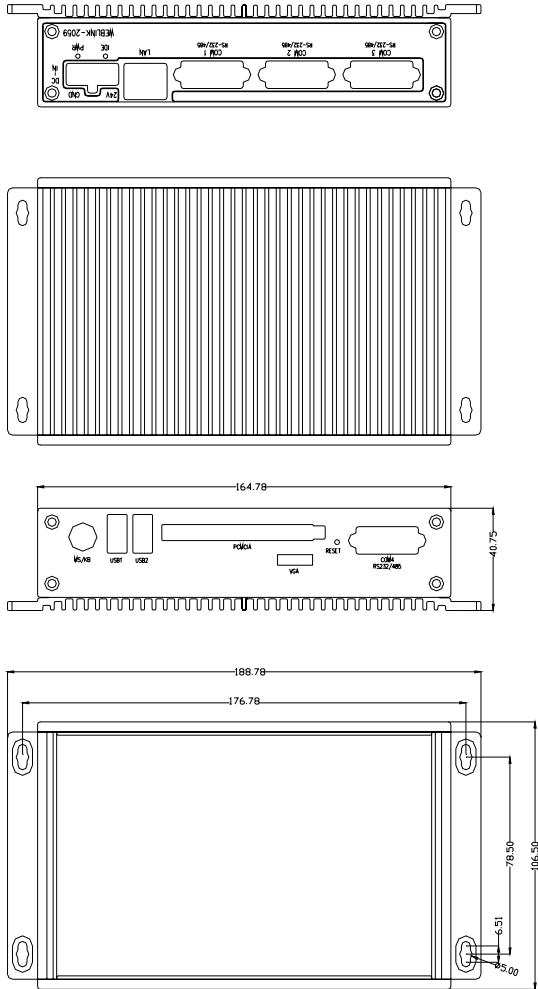

**Figure 1.1: Chassis Dimensions**

## Hardware Functionality

This chapter shows how to set up the UNO-2050E's hardware functions, including connecting peripherals, switches and indicators.

Sections include:

- UNO-2050E Peripherals
- COM1 & 2: RS-232 Interfaces
- COM3 & 4: Isolated 5-wire RS-232/422/485
- Onboard Isolated Digital Input
- Onboard Isolated Digital Output
- Onboard Isolated Counter/Timer
- LAN: Ethernet Connector
- Power Connector
- LED Indicators
- PS/2 Keyboard and Mouse Connector
- VGA: VGA Display Connector
- Programmable LED and Buzzer for System Diagnosis
- RESET: Reset Button

## 2.1 UNO-2050E Peripherals

---

The following two figures show the connectors on UNO-2050E. The following sections give you detail information about function of each peripheral.

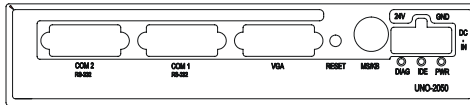

*Figure 2.1: UNO-2050E Front Panel*

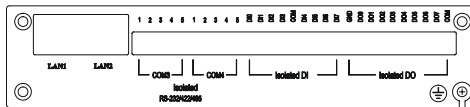

*Figure 2.2: UNO-2050E Rear Panel*

## 2.2 COM1 & 2: RS-232 Interfaces

---

The UNO-2050E offers two standard RS-232 serial communication interface ports, and they are COM1 and COM2. Please refer to A.2 for its pin assignments.

## 2.3 COM3 & 4: Isolated 5-wire RS-232/422/485

---

The UNO-2050E offers two isolated 5-wire RS-232/422/485 serial communication interface ports, and they are COM3 and COM4. The connector type of COM3 and COM4 is screw-terminal block that it's easy for wiring without additional daughter board. Each port can be configured individually to either RS-232, RS-422 or RS-485 by using on-board jumpers (see Appendix A.3), and Table 2-1 lists the default setting of each port.

**Table 2.1: Serial Port Default Setting**

COM Port	Default Setting
COM3	RS-485
COM4	RS-485

## 16C954 UARTs with 128-byte Standard

Advantech UNO-2050E comes standard with Oxford OX16PCI964 UARTs containing 128 bytes FIFOs. These upgraded FIFOs greatly reduce CPU overhead and are an ideal choice for heavy multitasking environments.

## Automatic Data Flow Control Function for RS-485

In RS-485 mode, UNO-2050E automatically senses the direction of incoming data and switches its transmission direction accordingly. Therefore no handshaking signal (e.g. RTS signal) is necessary. This feature lets you simply and quickly build an RS-485 network with just two wires. More importantly, application software previously written for half duplex RS-232 environments can be maintained without need for modification.

## IRQ and Address Setting

The IRQ and I/O address range are both assigned by BIOS. COM3, COM4 serial ports and on-board digital I/O use the same IRQ.

## 2.4 Onboard Isolated Digital Input

---

The UNO-2050E has 8 isolated digital input channels designated DI0~DI7.

### Pin Assignments

The connector type of UNO-2050E is plug-in screw terminal block that enables you to connect to field I/O devices directly without additional accessories. Figure 2-3 and Table 2-2 shows its pin assignment as well as signal description.

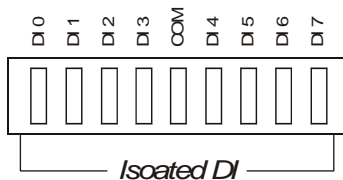

*Figure 2.3: Digital Input Connector Pin Assigns*

**Table 2.2: Digital Input Signal Description**

Signal Name	Reference	Direction	Description
DI <0...7>	COM	Input	Isolated digital input signals
COM	-	Input	External common input of DI

### Isolated Inputs

Each of isolated digital input channels accepts 10 ~ 50 V<sub>DC</sub> voltage inputs, and accepts bi-directional input. It means that you can apply positive or negative voltage to an isolated input pin (Vin). All eight channels share one common pin (COM). Figure 2-4 shows how to connect an external input source to one of the UNO-2050E's isolated input channels.

Please note that DI4 and DI5 may be configured as Counter 0 and Counter 1's gate control pins; DI6 and DI7 may be configured as Counter 0 and Counter 1's clock input pins. Please refer to "Section 2.6" for detail

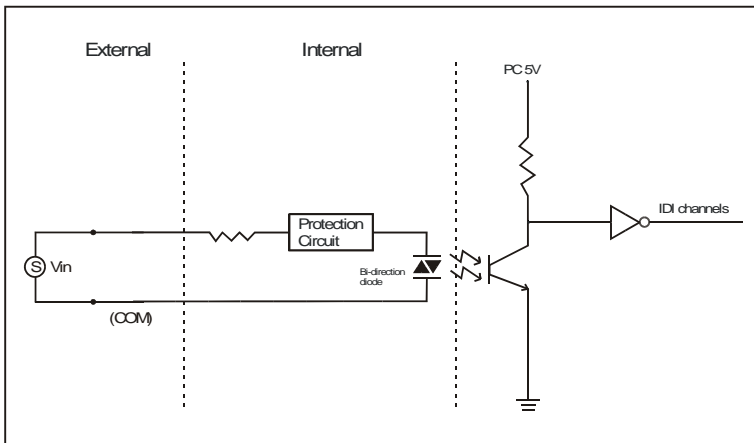

**Figure 2.4: Isolated Digital Input Connection**

## Interrupt Function of the DI Signals

DI0 and DI1 can be used to generate hardware interrupts. A user can setup the configuration of interrupts by programming the interrupt control register.

The channels are connected to the interrupt circuitry. Users can disable/enable interrupt function, select trigger type or latch the port data by setting the Interrupt Control Register of the UNO-2050E. When the interrupt request signals occur, then the software will service these interrupt requests by ISR (Interrupt Service Routine). The multiple interrupt sources provide the card with more capability and flexibility.

## IRQ Level

The IRQ level is set automatically by the system BIOS. There is no need for users to set the IRQ level. Only one IRQ level is used although it has several interrupt sources.

## Interrupt Control Register

The Interrupt Control Register controls the function and status of each interrupt signal source. Table 2-3 shows the bit map of the Interrupt Control Register. The register is readable/writable register. While being written, it is used as a control register; and while being read, it is used as a status register

**Table 2.3: Interrupt Control Register Bit Map**

Base Address		7	6	5	4	3	2	1	0
Base+02H	R/W	Interrupt Enable Control/Status Register							
								DI1EN	DI0EN
Base+03H	R/W	Interrupt Triggering Edge Control/Status Register							
								DI1TE	DI0TE
Base+07H	R/W	Interrupt Flag/Clear Register							
								DI1F	DI0F

DI0EN & DI1EN: DI0 & DI1 Interrupt disable/enable control bit

DI0TE & DI1TE: DI0 & DI1 Interrupt triggering edge control bit

DI0F & DI1F: DI0 & DI1 interrupt flag bit

## Interrupt Enable Control Function

The user can choose to enable or disable the interrupt function by writing its corresponding value to the interrupt disable/enable control bit in the interrupt control register, as shown in Table 2-4

**Table 2.4: Interrupt Disable/Enable C. Bit Values**

<b>DI0EN &amp; DI1EN</b>	<b>Interrupt Disable/Enable Control</b>
0	Disable
1	Enable

## Interrupt Triggering Edge Control

The interrupt can be triggered by a rising edge or a falling edge of the interrupt signal, as determined by the value in the interrupt triggering edge control bit in the interrupt control register, as shown in Table 2-5.

**Table 2.5: Interrupt Triggering Edge C. Bit Values**

<b>DI0TE &amp; DI1TE</b>	<b>Triggering Edge of Interrupt Signal</b>
0	Falling edge trigger
1	Rising edge trigger

## Interrupt Flag Bit

The interrupt flag bit is a flag indicating the status of an interrupt. It is a readable/writable bit. To find the status of the interrupt, you have to read the bit value; to clear the interrupt, you have to write “1” to this bit. This bit must first be cleared to service the next coming interrupt

**Table 2.6: Interrupt Flag Bit Values**

<b>DI0F &amp; DI1F</b>		<b>Interrupt Status</b>
Read	0	No interrupt
	1	Interrupt occur
Write	0	Don't care
	1	Clear interrupt.

## 2.5 Onboard Isolated Digital Output

The UNO-2050E has 8 isolated digital output channels designated DO0~DO7.

### Pin Assignment

The connector type of UNO-2050E is plug-in screw terminal block that enables you to connect to field I/O devices directly without additional accessories. Figure 2-5 and Table 2-7 shows its pin assignment as well as signal description.

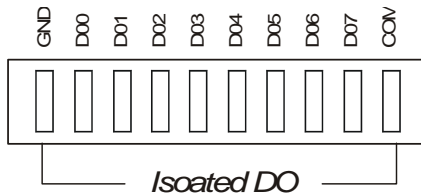

Figure 2.5: Digital Output Connector Pin Assigns

Table 2.7: Digital Output Signal Description



Signal Name	Reference	Direction	Description
DO <0...7>	COM	Output	Isolated digital output signals
COM	-	Input	External common output of DO
GND	-	-	Isolated ground

### Power On Configuration

Default configuration after power on or hardware reset is to set all the isolated digital output channels to open status (the current of the load can't be sink) so that users need not worry about damaging external devices during system startup or reset.

When the system is hot reset, then the status of isolated digital output channels are selected by jumper JP12. Table 2-8 shows the configuration of jumper JP12.

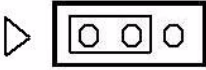
**Table 2.8: JP12 DO Power On Configuration**

JP12	Power on Configuration after Hot Reset
	Default configuration
	Keep last status after hot reset

### Isolated Outputs

Each of isolated output channels comes equipped with a Darlington transistor. All eight output channels share common collectors and integral suppression diodes for inductive loads.

Please note that if an external voltage ( $5 \sim 40 V_{DC}$ ) is applied to an isolated output channel while it is being used as an output channel, the current will flow from the external voltage source to the UNO-2050E. Please take care that the current through each DO pin not exceed 200 mA.

Figure 2-6 shows how to connect an external output load to the UNO-2050E's isolated outputs.

Please note that DO6 and DO7 may be configured as Counter 0 and Counter 1's output pins, please refer to "Section 2.6" for detail.

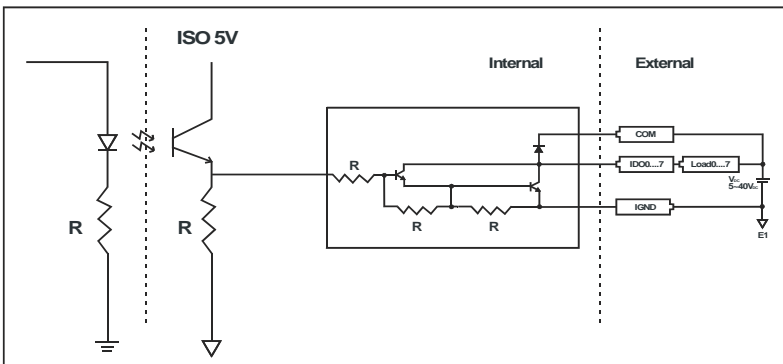

**Figure 2.6: Isolated Digital Output Connection**

## 2.6 Onboard Isolated Counter/Timer

---

The UNO-2050E uses one 82C54 programmable timer/counter chip that includes three independent 16-bit down counters: counter 0, counter 1 and counter 2. Counter 0 and counter 1 are for users, and counter 2 is specified for the system and can't be used by user. Each counter has clock input, gate input and pulse output. They can be programmed to count from 2 up to 65535 or cascaded into one 32-bit counter.

The UNO-2050E has 2 isolated counter input channels designated DI6 and DI7 or 2 isolated timer output channels designated DO6 and DO7. Therefore, you can set each counter of 82C54 as counter function or timer function.

## Counter/Timer Control Register

The Counter/Timer Control Register controls the function and status of each counter/timer signal source. Table 2-9 shows the bit map of the Counter/Timer Control Register. The register is readable/writable register. While being written, it is used as a control register; and while being read, it is used as a status register

**Table 2.9: Counter/Timer Control Register Bit Map**

Base Address	7	6	5	4	3	2	1	0
Base+07H	R/W	Interrupt Flag/Clear Register						
						CTR1F	CTR0F	
Base+08H	R/W	82C54 Chip Counter0 Register						
Base+09H	R/W	82C54 Chip Counter1 Register						
Base+0BH	R/W	82C54 Chip Control Register						
Base+0CH	R/W	Counter0 Start Control / Output Status Register						
					CTR0 Out			
Base+0DH	R/W	Counter1 Start Control / Output Status Register						
					CTR1 Out			
Base+0EH	R/W	Counter0 Setting Register						
						CTR0 IntSet	CTR0 OutSet	CTR0 GateSet
Base+0FH	R/W	Counter1 Setting Register						
			CTR32 Set	S1	S0	CTR1 IntSet	CTR1 OutSig	CTR1 GateSig

CTR0F & CTR1F: Counter 0 & Counter 1 interrupt flag bit

CTR0Gate & CTR1Gate: Counter 0 and Counter 1 gate control bit

CTR0Out & CTR1Out: Counter 0 and Counter 1 output status bit

CTR0CLKSet & CTR1CLKSet: Counter 0 and 1 clock source control bit

CTR0GateSet & CTR1GateSet: Counter 0 and 1 gate source control bit

CTR0OutSet & CTR1OutSet: Counter 0 & 1 output destination controlbit

CTR0IntSet & CTR1IntSet: Counter 0 and Counter 1 interrupt control bit

S0 & S1: Counter 0 and 1 internal clock control bit

CTR32Set: Cascaded 32-bit counter control bit

## Counter 0 Function Block

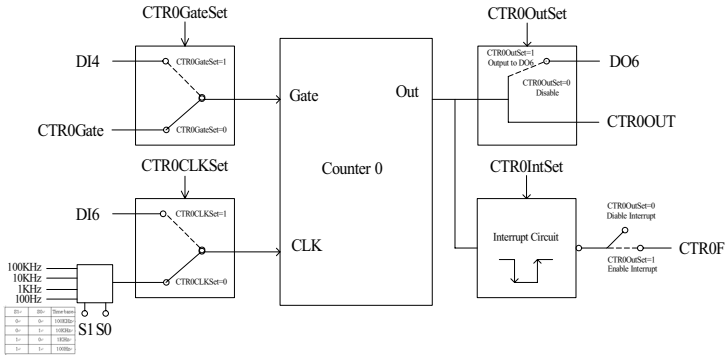

Figure 2.7: Counter 0 Function Block

## Counter 1 Function Block

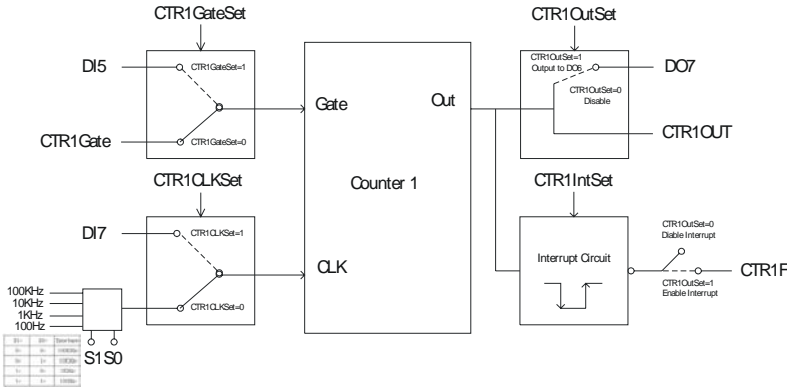
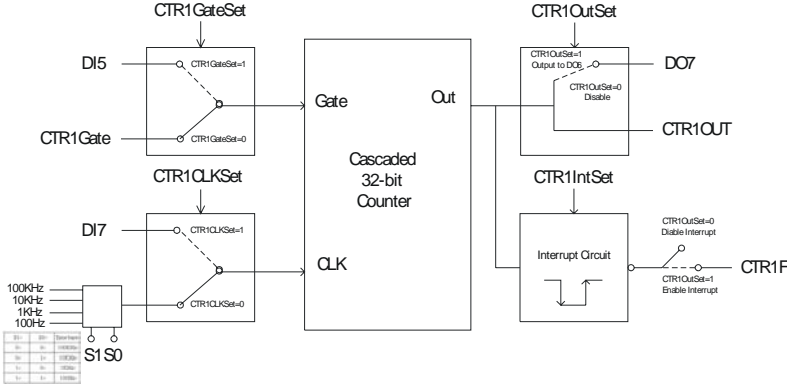

Figure 2.8: Counter 1 Function Block

### 32-bit Counter Function Block (CTR32Set=1)



**Figure 2.9: 32-bit Counter Function Block**

### Counter Clock Source

There are two clock sources available for the user counters by setting counter clock control bits - CTR0CLKSet and CTR1CLKSet.

**Table 2.10: Counter Clock Source Control Bit**

CTR0CLKSet	0	Internal clock (default)
	1	External clock from digital input 6 (DI6) channel
CTR1CLKSet	0	Internal clock (default)
	1	External clock from digital input 7 (DI7) channel

### Counter Internal Clock

There are four frequency options to choose according to applications, and it's set by internal clock control bits - S0 and S1.

**Table 2.11: Counter Internal Clock Control Bit**

S1	S0	Time Base
0	0	100 KHz (default)
0	1	10 KHz
1	0	1 KHz
1	1	100 Hz

## Counter Gate Source

The gate sources you select determine what kind of gate input signal to enable your counter/timer when receiving clock input. There are two gate sources available for the user counters by setting gate source control bits - CTR0GateSet and CTR1GateSet.

**Table 2.12: Counter Gate Source Control Bit**

CTR0 GateSet	0	Gate source from “CTR0Gate” control bit (Default)
	1	Gate source from digital input 4 (DI4) channel
CTR1 GateSet	0	Gate source from “CTR1Gate” control bit (Default)
	1	Gate source from digital input 5 (DI5) channel

## Counter Output Destination

You can choose the output destination of counter 0 and counter 1 by setting “Output Destination control bits” - CTR0OutSet and TR1OutSet.

**Table 2.13: Counter Output Destination**

CTR0 OutSet	0	Output destination to “CTR0Out” status bit (Default)
	1	Output destination to “CTR0Out” status bit and digital output 6 (DO6) channel
CTR1 OutSet	0	Gate destination to “CTR1Out” status bit. (Default)
	1	Output destination to “CTR1Out” status bit and digital output 7 (DO7) channel

## Counter Interrupt Flag

The interrupt flag bit is a flag indicating the status of an interrupt. It is a readable/writable bit. To find the status of the interrupt, you have to read the bit value; to clear the interrupt, you have to write “1” to this bit. This bit must first be cleared to service the next coming interrupt. Besides, you can choose if counter 0 or counter 1 generate interrupt signal by configuring “CTR0IntSet” and “CTR1IntSet” control bit.

**Table 2.14: Counter Interrupt Flag Control Bit**

CTR0F, CTR1F		Counter Interrupt Status
Read	0	No interrupt
	1	Interrupt occur
Write	0	Don't care
	1	Clear interrupt
CTR0IntSet, CTR1IntSet		Counter Interrupt Control
0		Disable (Default)
1		Enable

## Cascaded 32-bit Counter

You can also cascade counter 0 and counter 1 together as one 32-bit counter/timer, and it's configured by the control bit - CTR32Set.

**Table 2.15: 32-bit Counter Control Bit**

0	Disable (Default)
1	Cascade counter 0 and counter 1 into one 32-bit counter

## 2.7 LAN: Ethernet Connector

---

The UNO-2050E is equipped with two Realtek RTL8139DL Ethernet LAN controller that is fully compliant with IEEE 802.3u 10/100Base-T CSMA/CD standards. The Ethernet port provides a standard RJ-45 jack on board, and LED indicators on the front side to show its Link (Yellow LED) and Active (Green LED) status. Please refer to A.4 for its pin assignments.

## 2.8 Power Connector

---

The UNO-2050E comes with a Phoenix connector that carries 9 ~ 30  $V_{DC}$  external power input, and features reversed wiring protection.

Therefore, it will not cause any damage to the system by reversed wiring of ground line and power line. Please refer to A.5 for its pin assignments.

## 2.9 LED Indicators

---

There are two LEDs on the UNO-2050E front panel for indicating system status: PWR LED is for power status and IDE LED is for IDE bus status.

## 2.10 PS/2 Keyboard and Mouse Connector

---

The UNO-2050E provides a PS/2 keyboard and PS/2 mouse connector. A 6-pin mini-DIN connector is located on the panel of the UNO-2050E. The UNO-2050E comes with an adapter to convert from the 6-pin mini-DIN connector to two 6-pin mini-DIN connectors for PS/2 keyboard and PS/2 mouse connection. Please refer to Appendix A.6 for its pin assignments.

## 2.11 VGA: VGA Display Connector

---

The UNO-2050E provides a VGA controller for a high resolution VGA interface. It supports VGA and VESA, up to 1280 x 1024 @ 8 bit and 1024 x 768 @ 24 bit resolution and up to 16 MB share memory. The VGA interface is reserved for system testing and debugging.

## 2.12 Programmable LED and Buzzer

---

In an application without monitor display, it is always a problem to know the system status. Another PC may be needed to monitor headless device status via RS-232 or Ethernet. In order to solve this problem, UNO-2050E offers a programmable LED indicator and buzzer.

**Table 2.16: LED & Buzzer Control Register Bit Map**

Base+10H	R/W	LED Control Register					
						LEDS1	LEDS0
Base+11H	R/W	Buzzer Control Register					
						SPKS1	SPKS0

## LED and Buzzer Control Register

LEDEn: Enable LED flickering

LEDS0 and LED1: LED flickering speed setting bit

SPKE n: Enable buzzer alarming

SPKS0 & SPKS1: Buzzer alarming setting bit

**Table 2.17: Programmable LED Control Bit**

LED Flickering Status	LEDS1	LEDS0
Light on	0	0
Fast flickering	0	1
Normal flickering	1	0
Slow flickering	1	1

**Table 2.18: Programmable Buzzer Control Bit**

Buzzer Alarm	SPKS1	SPKS0
Beep on	0	0
Short beep	0	1
Normal beep	1	0
Long beep	1	1

## 2.13 RESET: Reset Button

---

Press “RESET” button will activate a reset function.

## **Initial Setup**

This chapter shows how to initial the UNO-2050E, sections include:.

Sections include:

- Insert CompactFlash Card
- Chassis grounding
- Connect the Power
- Wiring Considerations
- BIOS Setup and System Assignments

# Chapter 3 Initial Setup

## 3.1 Insert CompactFlash Card

---

The procedure for installing a CompactFlash card into the UNO-2050E is as follows, please follows these steps carefully.

**Step 1:** Remove power cord.

**Step 2:** Unscrew four screws from the rear panel of the UNO-2050E.

**Step 3:** Remove the rear panel.

**Step 4:** Plug a CompactFlash card with user's OS and application program into a CompactFlash card slot on board.

**Step 5:** Screw back the rear panel with four screws.

## 3.2 Chassis Grounding

---

The UNO-2050E housing is aluminum material that provides good EMI protection and a stable system grounding base. Users can select if connecting power grounding with chassis grounding with an onboard jumper selection.

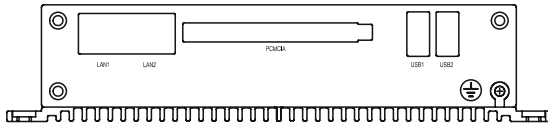

*Figure 3.1: Chassis Grounding Connection*

UNO-2050E has onboard jumper JP2 to select if connecting chassis ground with system's power ground.

Connecting chassis ground with system power ground: (Default)

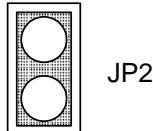

Not connecting chassis ground with system power ground:

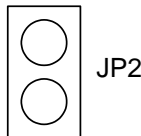

### 3.3 Connect the Power

---

Connect the UNO-2050E to a  $9 \sim 30 V_{DC}$  power source. The power source can either be from a power adapter or an in-house power source.

### 3.4 Wiring Considerations

---

There are several I/O interfaces use a plug-in screw terminal block for the interface between I/O modules and field devices.

The following information must be considered when connecting electrical devices to I/O modules.

1. The terminal block accepts wires from 0.5 mm to 2.5 mm.
2. Always use a continuous length of wire. Do not combine wires to make them longer.
3. Use the shortest possible wire length.
4. Use wire trays for routing where possible.
5. Avoid running wires near high-energy wiring.
6. Avoid running input wiring in close proximity to output wiring where possible.
7. Avoid creating sharp bends in the wires.

### 3.5 BIOS Setup and System Assignments

---

UNO-2050E adopts Advantech SOM-2354 CPU module. For UNO-2050E BIOS setup and system assignments, you can refer to SOM-2354 Chapter 4 “Award BIOS Setup” and Appendix A “System Assignments” for detailed information. The SOM-2354 user’s manual is located under “Manual” folder on the CD-ROM.”

Please note that you can try to “LOAD BIOS DEFAULTS” from BIOS Setup manual if the UNO-2050E does not work properly.

## 3.6 HDD Extension Flexibility

---

Although UNO-2050E is an embedded platform, there is reserve flexibility to install one 2.5" HDD. Some customers want to install a popular operating system, like Windows 2000/XP or need for larger data storage capability. UNO-2050E is also an ideal platform for applications with HDD demand. Please contact Advantech to purchase UNO-2050E's HDD extension kit.

## Pin Assignments

This appendix gives the UNO-2050E pin assignments.

Sections include:

- Board Connectors and Jumpers
- Standard RS-232 Serial Port
- Isolated 5-wire RS-232/422/485 Serial Port
- Ethernet RJ-45 Connector
- Phoenix Power Connector
- PS/2 Keyboard and Mouse Connector
- VGA Display Connector
- CompactFlash Settings
- Enhanced IDE connector
- LCD connector (Reserved)
- Audio connector (Reserved)

# Appendix A Pin Assignments

## A.1 Board Connector and Jumpers

There are connectors and jumpers on the UNO-2050E board. The following sections tell you how to configure the UNO-2050E hardware setting. Figure A-1 and figure A-2 show the locations of UNO-2050E connectors and jumpers.

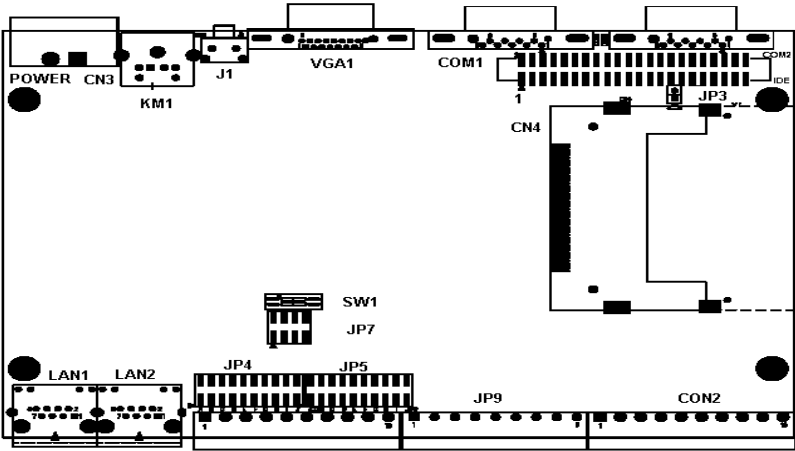

Figure A.1: Connector & Jumper Locations (Top)

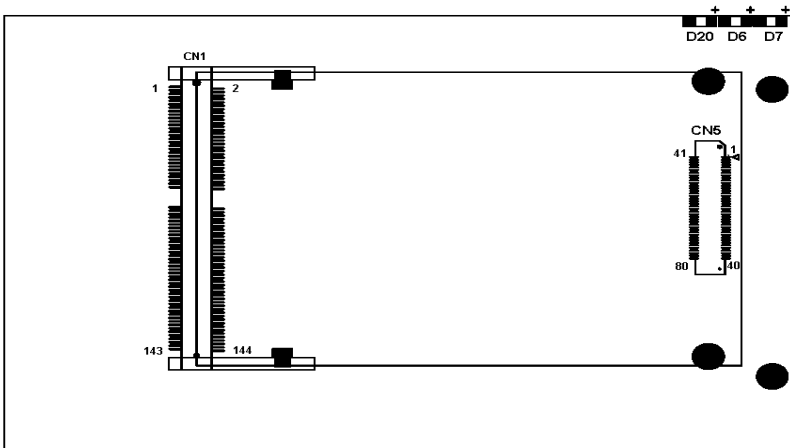

Figure A.2: Connector & Jumper Locations (Bottom)

**Table A.1: UNO-2050E Connectors & Jumpers**

CN2	Internal IDE connector
CN3	Phoenix power connector
CN4	Internal CompactFlash card slot
COM1	COM1 standard RS-232 serial port
COM2	COM2 standard RS-232 serial port
CON1	COM3&4 Isolated 5-wire RS-232/422/485 serial connector
CON2	Isolated digital output connector
D6	Power IDE LED
D7	Power LED
D20	Diagnostic LED
J1	Reset button
JP2	System grounding mode
JP3	CompactFlash IDE Primary Master/Slave jumper
JP4	COM3 5-wire RS-232/422/485 selection
JP5	COM4 5-wire RS-232/422/485 selection
JP7	RS-422/485 terminal resistor setting
JP9	Isolated digital input connector
JP11	Digital output power on configuration
KM1	PS/2 keyboard and mouse connector
LAN1	Ethernet RJ-45 connector
LAN2	Ethernet RJ-45 connector
SW1	RS-485 auto flow control mode and RS-422 master/slave mode connector
VGA1	VGA DB-15 connector

## A.2 Standard RS-232 Serial Port

---

### Pin Assignments

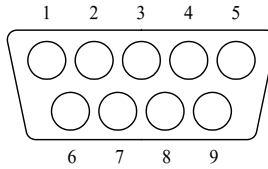
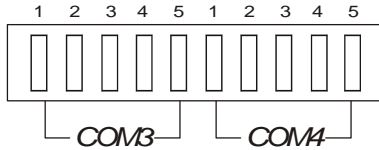

**Table A.2: RS-232 Serial Port Assignments**

Pin	RS-232 Signal Name
1	DCD
2	RxD
3	TxD
4	DTR
5	GND
6	DSR
7	RTS
8	CTS
9	RI

## A.3 Isolated RS-232/422/485 Ports

### Pin Assignments



**Table A.3: Isolated RS-232/422/485 Port Assigns**

Pin	5-wire RS-232 Signal Name	RS-422 Signal Name	RS-485 Signal Name
1	RxD	TxD+	DATA+
2	TxD	TxD-	DATA-
3	RTS	RxD+	NC
4	CTS	RxD-	NC
5	GND	GND	GND

*Note:* NC represents “No Connection.”

### RS-232/422/485 Selection

COM3 and COM4 support 5-wire RS-232, RS-422 or RS-485 interfaces, and you can set corresponding jumpers to select serial ports as RS-232 or RS-422/485 interfaces shown in Table A-4.

The system detects RS-422 or RS-485 signals automatically in RS-422/485 mode.

**Table A.4: Jumpers to Select RS-232/422/485**

Serial Port	Corresponding jumper to select RS-232/422/485
COM3	JP4
COM4	JP5

**Jumper Setting for RS-422/485 Interface: (Default Setting)**

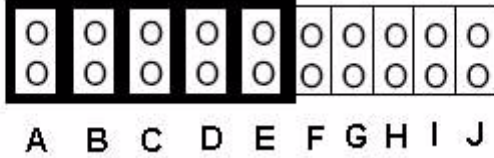

**Jumper Setting for RS-232 Interface:**

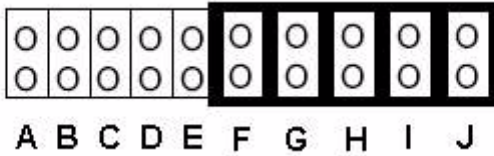

**RS-485 Auto Flow Control & RS-422 Master/Slave Mode Selection**

You set the “Auto Flow Control” mode of RS-485 or “Master/Slave” mode of RS-422 by using SW1 DIP switches for each RS-422/485 port.

In RS-485, if the switch is set to "Auto", the driver automatically senses the direction of the data flow and switches the direction of transmission. No handshaking is necessary.

In RS-422, if DIP switch is set to "On," the driver is always enabled, and always in high or low status.

**Table A.5: Auto Flow&Master/Slave Select**

SW1 DIP Switch Setting	Description
	COM3 RS-485: Auto flow control; RS-422: Slave mode
	COM4 RS-485: Auto flow control; RS-422: Slave mode
	COM3 RS-485: N/A; RS-422: Master mode
	COM4 RS-485: Auto flow control; RS-422: Slave mode
	COM3 RS-485: Auto flow control; RS-422: Slave mode
	COM4 RS-485: N/A; RS-422: Master mode
	COM3 RS-485: N/A; RS-422: Master mode
	COM4 RS-485: N/A; RS-422: Master mode

## Terminator Resistors Setup for RS-422/485

The 120Ω terminal resistors for impedance matching on the UNO-2050E are installed on board by selecting jumper JP7. Each terminal resistor corresponds to different channels for RS-422/485 signal lines. Usually, these resistors are needed for both ends of the communication wires and the value of the resistors should match the characteristic impedance of the wires used.

**Table A.6: JP7 RS-422/485 Terminal Resistor Setting**

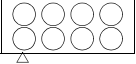
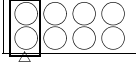
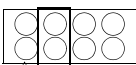
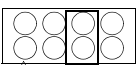
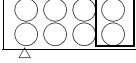
JP7	Enable Pins
	Default setting - No terminal resistors
	COM3 Pin1 and Pin2 connect with 120Ω terminal resistors
	COM3 Pin3 and Pin4 connect with 120Ω terminal resistors
	COM4 Pin1 and Pin2 connect with 120Ω terminal resistors
	COM4 Pin3 and Pin4 connect with 120Ω terminal resistors

## RS-485 Signal Wiring

The RS-485 standard supports half-duplex communication. This means that just two wires are needed to both transmit and receive data. Handshaking signals (such as RTS, Request To Send) in RS-232 are normally used to control the direction of the data flow and to switch the transmission accordingly. In RS-485 mode, the UNO-2050E automatically senses the direction of the data flow and switches the transmission direction - no handshaking is necessary. This means a user can build an RS-485 network with just two wires. This RS-485 control is completely transparent to the user. The software written for half duplex RS-232 works without the need for any modification.

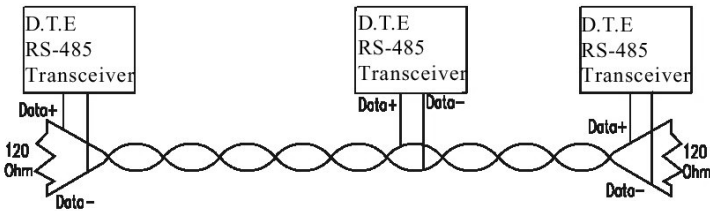

Figure A.3: RS-485 Wiring Topology

## A.4 Ethernet RJ-45 Connector (LAN1~LAN2)

### Ethernet RJ-45 Connector Pin Assignments

Table A.7: Ethernet RJ-45 Connector Pin Assigns

Pin	10/100Base-T Signal Name
1	XMT+
2	XMT-
3	RCV+
4	NC
5	NC
6	RCV-
7	NC
8	NC

## A.5 Phoenix Power Connector (CN3)

---

### Phoenix Power Connector Pin Assignments

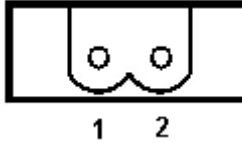

**Table A.8: Phoenix Power Connector Pin Assigns**

Pin	Signal Name
1	+9~30 V <sub>DC</sub>
2	GND

## A.6 PS/2 Keyboard & Mouse Connector

---

### PS/2 KB/MS Connector Pin Assignments

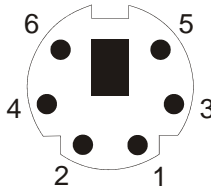

**Table A.9: Keyboard & Mouse Connector Pin Assigns**

Pin	Signal Name
1	KB DATA
2	MS DATA
3	GND
4	VCC
5	KB CLOCK
6	MS CLOCK

## A.7 VGA Display Connector (VGA1)

---

### VGA Connector Pin Assignments

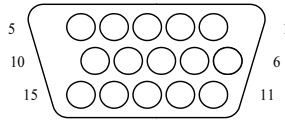

**Table A.10: VGA Adaptor Cable Pin Assigns**

Pin	Signal Name	Pin	Signal Name
1	RED	9	NC
2	GREEN	10	GND
3	BLUE	11	NC
4	NC	12	NC
5	GND	13	H-SYNC
6	GND	14	V-SYNC
7	GND	15	NC
8	GND		

### Chipset

The UNO-2050E uses a AMD CS5535 chipset for its SVGA controller. It supports interlaced and non-interlaced analog monitors (color and monochrome VGA) in high-resolution modes while maintaining complete IBM VGA compatibility. Digital monitors (i.e. MDA, CGA and EGA) are NOT supported. Multiple frequency (multisync) monitors are handled as if they were analog monitors.

### Display Memory

With 1 ~ 16 MB share memory, the VGA controller can drive CRT displays or color panel displays with resolutions up to 1024 x 768 at 32 bit. For 1024 x 768 color resolution, the display is expanded to 16 MB in BIOS.

## **A.8 CompactFlash Master/Slave Jumper Settings (JP3)**

The CompactFlash interface uses a primary IDE channel, which could be set as the master or slave device by changing the setting of JP3.

### **Master Device: (Default)**

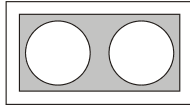

JP3

### **Slave Device:**

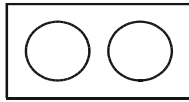

JP3

UNO-2050E has one internal CompactFlash card slot and one external CompactFlash card slot. Internal CompactFlash card slot supports CompactFlash type I (3mm thick) only and External CompactFlash card slot supports both Type I and type II (5mm thick) cards

A 128 MB CompactFlash card is equipped in the UNO-2050ECE with Windows CE .NET OS. For UNO-2050E, there is no CompactFlash card on the slot. UNO-2050E also supports IBM Microdrive storage device, which is an ultra-miniature hard disk from IBM that was introduced in 1998. The Microdrive is built into a Type II CompactFlash form factor.

A 1GB CompactFlash card is equipped in the UNO-2050EXP with Windows XPe OS. For UNO-2050E, there is no CompactFlash card on the slot. UNO-2050E also supports IBM Microdrive storage device, which is an ultra-miniature hard disk from IBM that was introduced in 1998. The Microdrive is built into a Type II CompactFlash form factor.

## A.9 Enhanced IDE Connector (CN2)

**Table A.11: IDE Hard Drive Connector**

Pin	Signal Name	Pin	Signal Name
1	IDE RESET	2	GND
3	DATA 7 (*2)	4	DATA 8 (*2)
5	DATA 6 (*2)	6	DATA 9 (*2)
7	DATA 5 (*2)	8	DATA 10 (*2)
9	DATA 4 (*2)	10	DATA 11 (*2)
11	DATA 3 (*2)	12	DATA 12 (*2)
13	DATA 2 (*2)	14	DATA 13 (*2)
15	DATA 1 (*2)	16	DATA 14 (*2)
17	DATA 0 (*2)	18	DATA 15 (*2)
19	SIGNAL GND	20	N/C
21	DMA REQUEST	22	GND
23	IO WRITE (*2)	24	GND
25	IO READ (*2)	26	GND
27	IO CHANNEL READY	28	GND (*1)
29	HDACK	30	GND
31	IRQ	32	N/C
33	ADDR 1	34	N/C
35	ADDR 0	36	ADDR 2
37	HARD DISK SELECT 0 (*2)	38	HARD DISK SELECT 1 (*2)
39	IDE ACTIVE	40	GND
41	VCC	42	VCC
43	GND	44	N/C

## A.10 UNO-2050E Control Register

**Table A.12: UNO-2050E Control Register**

Base Address		7	6	5	4	3	2	1	0
Base+00H	R	Isolated Digital Input Status Register							
		DI7	DI6	DI5	DI4	DI3	DI2	DI1	DI0
Base+01H	R/W	Isolated Digital Output Control/Status Register							
		DO7	DO6	DO5	DO4	DO3	DO2	DO1	DO0
Base+02H	R/W	Interrupt Enable Control/Status Register							
								DI1EN	DI0EN
Base+03H	R/W	Interrupt Triggering Edge Control/Status Register							
								DI1TE	DI0TE
Base+07H	R/W	Interrupt Flag/Clear Register							
						CTR1F	CTR0F	DI1F	DI0F
Base+08H	R/W	82C54 Chip Counter0 Register							
Base+09H	R/W	82C54 Chip Counter1 Register							
Base+0BH	R/W	82C54 Chip Control Register							
Base+0CH	R/W	Counter0 Start Control / Output Status Register							
					CTR0 Out				CTR0 Gate
Base+0DH	R/W	Counter1 Start Control / Output Status Register							
					CTR1 Out				CTR1 Gate
Base+0EH	R/W	Counter0 Setting Register							
						CTR0 IntSet	CTR0 OutSet	CTR0 GateSet	CTR0 CLKSet
Base+0FH	R/W	Counter1 Setting Register							
			CTR32Set	S1	S0	CTR1 IntSet	CTR1 OutSig	CTR1 GateSig	CTR1 CLKSig
Base+10H	R/W	LED Control Register							
							LEDS1	LEDS0	LEDEn
Base+11H	R/W	Buzzer Control Register							
							SPKS1	SPKS0	SPKEen

