

Standard Industrial Computer for 19" Racks 4U

- 19" Rack 4 units high
depth 450/500mm
- Steel construction
- Protection: IP40
- Door lock
- On/Off and reset switch
behind protecting door
- Versions:
14 Slot PCI/ISA passive
backplane + slot-CPU
- Space for 2 x 5,25" and
1 x 3,5" drives.
- Drives are mounted on
rubbers.
- Front fan with air filter
- Clamps for board fixing.

Description:

The PCQT-610 is a robust Industrial Computer with lots of space for expansion boards and drives. The choice is about 2 basic versions, the Slot-CPU and the ATX motherboard version.

The Chassis is designed for use in 19" Rack and desktops as well.

Specification:

Dimension: W x H x D
482 x 177 x 452 mm backplane +
Slot-CPU, respectively
482 x 177 x 502 mm ATX for mother-
boards

Weight: 19 kg

Colour: standard PCQT grey

Construction: steel

Drives: 2 x 5,25" and 1 x 3,5" minimum

Ventilation: 86CFM fan with dust filter
accessible from the front.

1 fan in power supply

Keyboard: ATX version: rear only

Slot-CPU version: front and rear.



On/Off, reset and LED indicators for power and harddisk are protected behind the lockable door.

Speaker: 8Ohm

Power supply :

Power between 250 and 550 W depending on configuration

Input: 90-132 VAC or 180-264 VAC,
47-63 Hz autosense or
90-264VAC with PFC

Minimum output :

+5V/ 30A, +3.3V/ 26A
(Max.220W für +5 und 3.3V)
+12V/ 13A
-12V/ 0.8A, -5V/ 0.5A
(Max. 0.8A für -12V und -5V)
+5VSB/ 2A

MTBF: 50000 hours @24h/d

Protection: UL/ CSA/ TÜV/ CE

Environmental Specification:

Operating temperature range:

P1, P3, PM: 5 to 50°C

P4: 5-40°C

Humidity: 5% to 95% at 40°C non
condensing.

Vibrations:

5-17 Hz @ 2,54ms and

17-500 Hz @ 1,5G accel pk/pk.

Socks: 10G/11mSec pk/pk

EMI: FCC/ VDE Class A

Order Information:

PCQT-610P/CPU/RAM/..

Slot-CPU version with
10Slot ISA+4Slot PCI
backplane and ATX
power supply

PCQT-610MB/ CPU/RAM/..

ATX motherboard version
with ATX power supply

Options:

-24VDC - 18-36V DC input

-12VDC - 10-18V DC input

- all kind of interfaces isolated/non
isolated

- different configuration



PCQT-610

Dimensions for version with backplane and slot-CPU

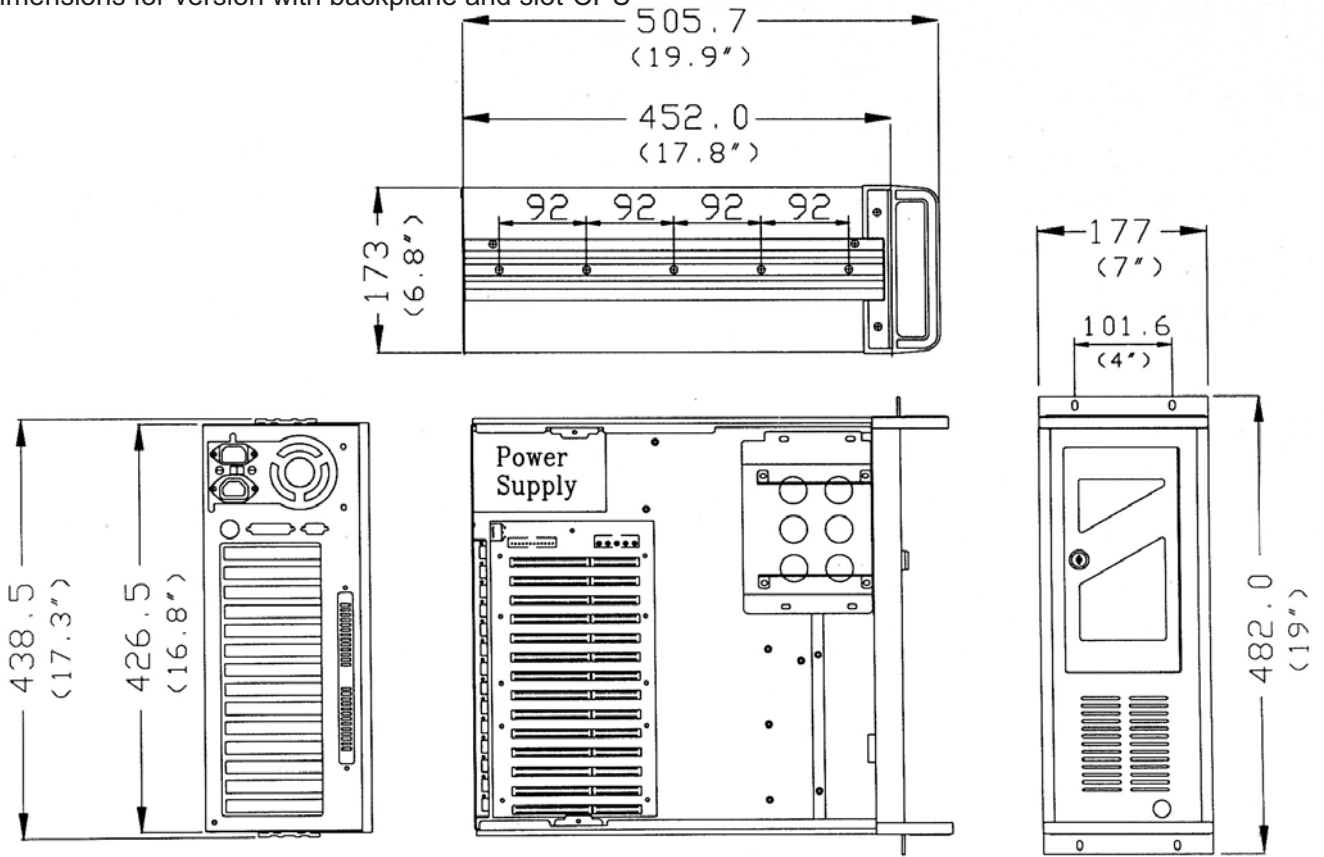

Dimensions for version with ATX motherboard

